

CL3000 PRINT & APPLY CASE LABELER

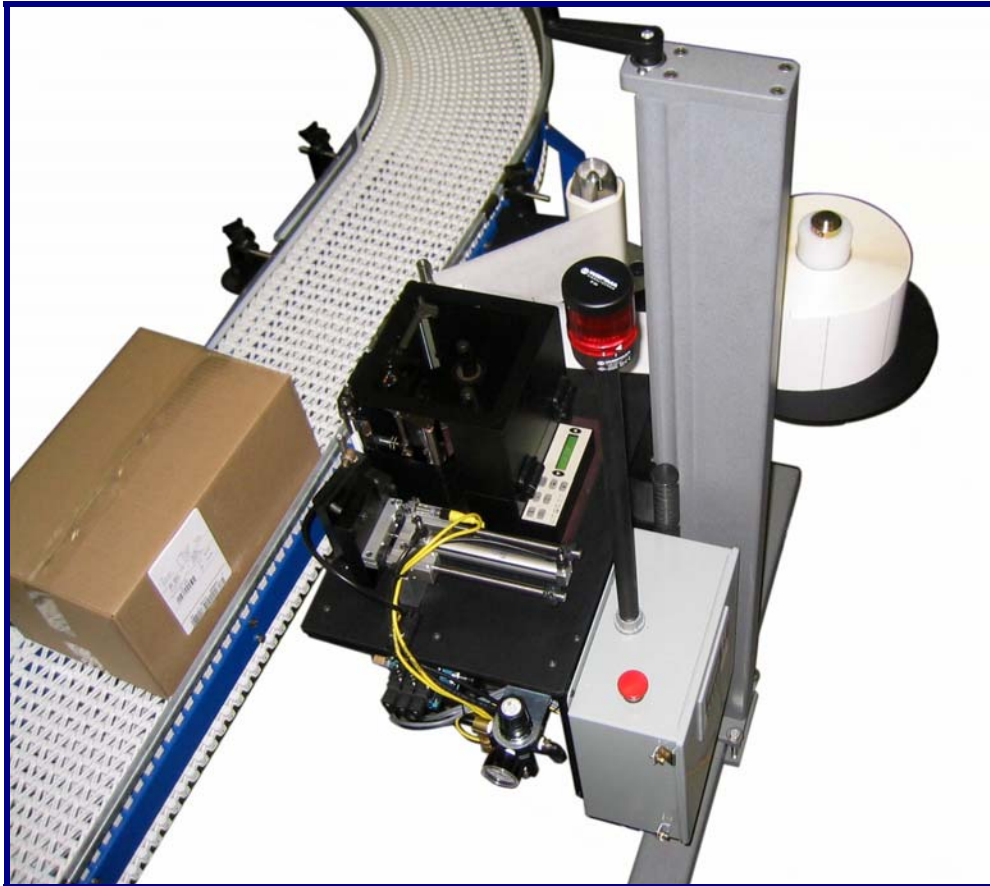

General Description

The CL3000 Print & Apply Case Labeler is designed to print and apply labels to the sides of cases at rates up to 45+ per minute. The machine is controlled by a high speed PLC, which can communicate with the conveyor or other product handling equipment. The PLC has a simple control panel with a four-line display allowing for quick set up and full diagnostic feedback.

The barcode labels are printed with a Zebra™ PAX print engine and are applied to the cases by a heavy-duty tamp assembly. The spring-loaded tamp-pad adapts to the case surface, wiping the label on as the case passes. The rugged PHD® slide-cylinder, the heavy-duty stand, the NEMA 12 industrial controls enclosure, and the other high quality commercial parts help ensure that the CL3000 will handle the rigors of 24/7 case labeling. Kolinahr Systems engineers can design a complete system to handle your case labeling needs.

CL3000 PRINT & APPLY CASE LABELER

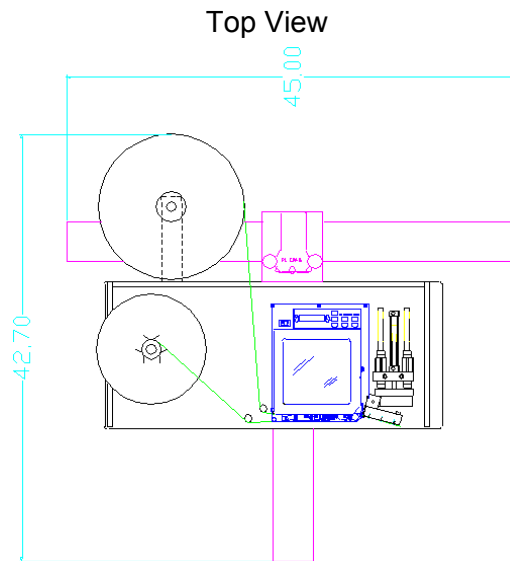

Specifications

Size (L x W x H)	45" x 42" x 67" (1.1 m x 1.1 m x 1.7 m)
Electrical	110 VAC, 60 Hz, Single phase, 10 A
Pneumatics	3 CFM (85 Lpm) @ 60 PSI (414 kPa) Clean Dry Air
Print Resolution	203/300 dpi (8/12 dots/mm)
Print Speed	12" (305 mm) per second maximum
Print Width	4.1" (104 mm) maximum
Media Width	4.5" (114 mm) maximum
Print Length	14" (355 mm) maximum
Label Specifications	12" (203 mm) O. D. on 3" (76 mm) I. D. cores Die-cut labels with 1/8" (3 mm) space
Ribbon Length	2955" (900 m)
Communication	RS-232/422/485 Serial Interface 10Mb Ethernet Interface

Options

16" (305 mm) O. D. on a 3" (76 mm) I. D. core label supply
Corner Wrap Applicator (CL3100)
Sato, Datamax, or other print engine
RFID printer upgrade for EPC™ compliance (CL3000-RF, CL3001-RF)
Lockable electrical disconnect and air dump
Customer-specified control system (Allen-Bradley PLC/SLC/CLX, Flex I/O, Modicon, more)

Kolinahr Systems, Inc.

6840 Ashfield Drive
Cincinnati, OH 45242

E-Mail: sales@kolinahr.cc
Phone: 513-745-9401
Fax: 513-794-3240
On the Web: <http://www.kolinahr.cc>

CL3000 PRINT & APPLY CASE LABELER

Standard Features	Benefits
Heavy-Duty Tamp Applicator	Applies labels to the side or top of cases Extremely durable PHD cylinder
Spring-Loaded Tamp Pad	Adjusts to variations on the surface of the case
PLC Machine Control	Control program can be customized for the application Can communicate with other product handling equipment Allows for full diagnostics feedback
Zebra® PAX Printer	High quality thermal transfer printing Easy to maintain or replace
Status Display Panel	Four line display allows full diagnostic feedback Makes set up and changeovers simple and easy
Fault Light	Provides a quick visual monitor for the operator
Media Status Indicators	Low-level and media fault detection minimizes downtime
High Grade Pneumatics	On/off controls minimize air usage by the vacuum pad/air assist system
Heavy-Duty T-Base Stand	Provides stable base for the machine Allows manual height adjustment



Kolinahr Systems, Inc.

6840 Ashfield Drive
Cincinnati, OH 45242

E-Mail: sales@kolinahr.cc
Phone: 513-745-9401
Fax: 513-794-3240
On the Web: <http://www.kolinahr.cc>